

## The Pro/ENGINEER® Suite of NC and Tooling Solutions

WHAT YOU NEED TO CAPITALIZE ON GLOBAL MANUFACTURING EXCELLENCE

To gain a competitive edge in product development, companies are increasingly leveraging globally distributed design teams and offshore manufacturing facilities. In this environment, enabling a smooth transition from product design to manufacturing is critical in order to achieve manufacturing excellence and successful product development. For machine shops both large and small, opportunities abound – that is, for those organizations with the tools and skills top manufacturers now demand.

With Pro/ENGINEER manufacturing tools for CAD/CAM, you have exactly what you need to win new business opportunities and lock out the competition. Easy to use, with unmatched power and performance, Pro/ENGINEER NC and Tooling solutions are the world standard – providing you with everything you need to achieve the highest quality, highest precision machining in the fastest possible time. Our complete family of applications can handle every aspect of the machine process, from mold design and advanced NC to 3D CAD simulation and verification.

Pro/ENGINEER machining solutions work alongside Pro/ENGINEER, giving you true concurrent design through manufacture. So you have the confidence knowing your parts are cut efficiently and accurately.

Put yourself in the best possible position to win new business, now emerging all across the globe by installing Pro/ENGINEER NC and Tooling solutions today.

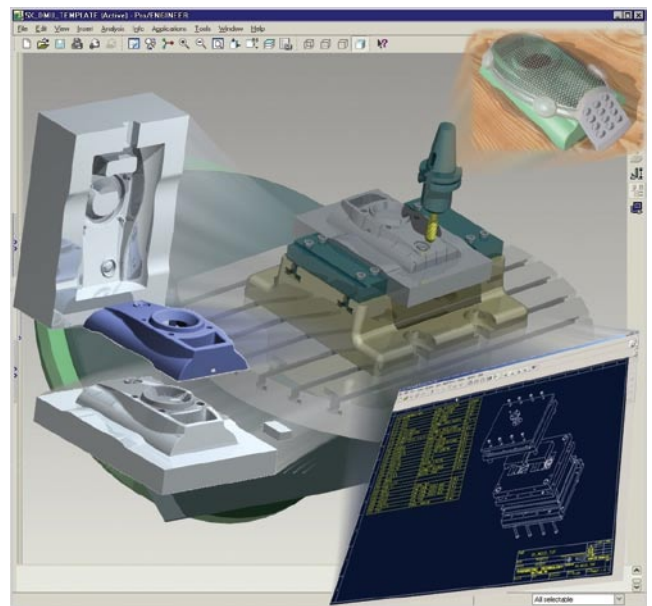

Go from 'art-to-part' with impressive speed using Pro/ENGINEER NC and Tooling solutions.

### The Complete Set of CAD Solutions—On a Single, Integrated Platform

The Pro/ENGINEER family of CAD/CAM/CAE software applications delivers a distinct advantage because every tool is fully 'associative': any change made to the design is automatically reflected in all downstream deliverables – without any translation of model information between applications. By eliminating data translation, you not only save time, but you also avoid potential errors in your design. No other 3D package offers such a complete set of native manufacturing applications – from tool and die design, to NC programming, process documentation, post-processing, and toolpath verification and simulation. Concurrent design and manufacturing is available only in Pro/ENGINEER.

# Pro/ENGINEER NC and Tooling Solutions

## Pro/ENGINEER CAM Solutions

### Pro/ENGINEER Prismatic and Multi-Surface Milling

Easy-to-use, feature-rich, and seamlessly integrated with design – Pro/ENGINEER Prismatic and Multi-Surface Milling is a virtual milling ‘specialist’ for prismatic production machining.

- Multi-surface 3-axis milling, with support for high-speed machining
- 4-axis and 5-axis positioning
- NC-program creation, process documentation, post-processing, and toolpath verification/simulation
- Improves product quality and manufacturing consistency by generating toolpaths directly on solid models
- Part of an integral CAD/CAM solution – no data translation required
- Reduces time-to-market via associative toolpath updates to design changes

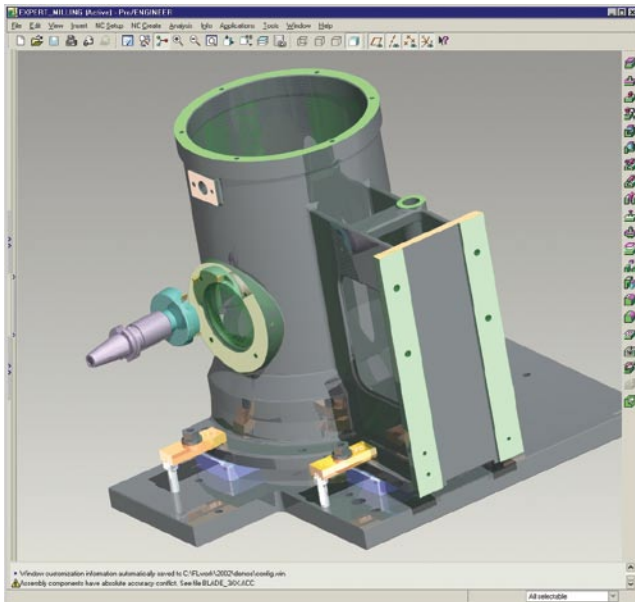

Four-axis milling in Pro/ENGINEER Prismatic and Multi-Surface Milling.

### Pro/ENGINEER Production Machining

In addition to robust NC programming capabilities spanning the functions of milling, turning, and wire EDM, Pro/ENGINEER Production Machining also offers seamless compatibility with design, which means that changes are automatically incorporated. The result: improved time-to-production and customer responsiveness.

- Includes all the capabilities of Pro/ENGINEER Prismatic and Multi-Surface Milling
- Supports CNC mills, 2-axis and 4-axis CNC lathes, and 2-axis and 4-axis CNC wire EDM machines
- Provides low-level NC sequence editing, allowing precise toolpath control and optimization
- Detailed step-by-step production planning instructions improve manufacturing efficiency and reduce development cost
- Optimized NC programming for families of designs accelerates time-to-volume production

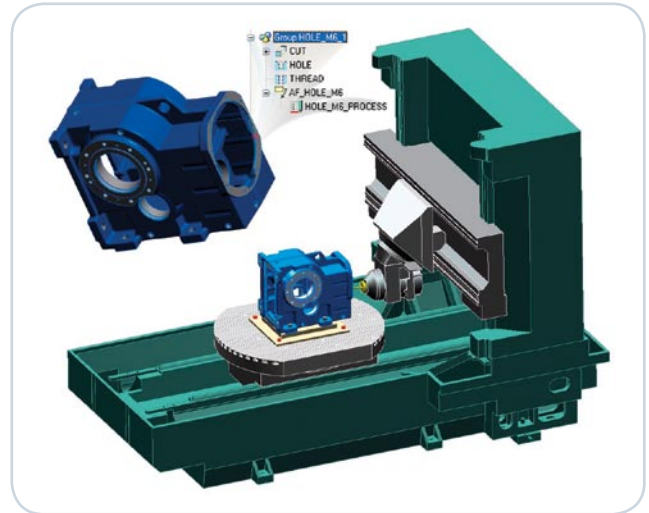

For production machining applications, Pro/ENGINEER Complete Machining provides automatic toolpath creation by extracting manufacturing annotation features.

### Pro/ENGINEER Complete Machining

Enjoy all the capabilities of Pro/ENGINEER Production Machining, along with multi-axis machining, plus full NC programming and extensive tool libraries. Now you can drive any type of CNC machine, including 2.5- to 5-axis mills, 2- to 4-axis lathes (synchronized or not), multi-axis mill/turn, and 2- to 4-axis wire EDM.

- 2.5- to 5-axis milling, multi-axis turning and mill/turn (live tooling); 4-axis wire EDM
- Simplifies storage and reuse of best practices by using proven manufacturing templates
- Improves product quality and manufacturing consistency by generating toolpaths directly on 3D designs
- Reduces time-to-market via associative tool-path updates to design changes
- Part of an integral CAD/CAM solution – no data translation required

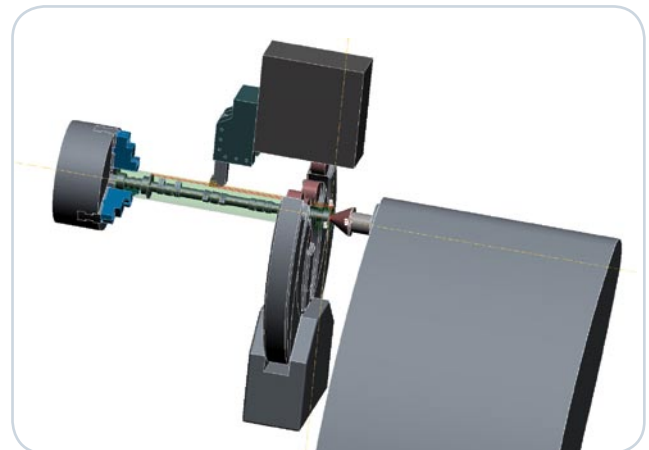

Two-axis turning in Pro/ENGINEER Production Machining.

## Tools for Adapting & Winning in Today's Competitive Market

### Pro/TOOLMAKER™

Optimize mold, die, prototype and other high-speed precision machining processes. Pro/TOOLMAKER quickly computes efficient, reliable NC toolpaths for even the most complex geometries, with highest-quality surface finishes.

- Delivers all high-speed precision machining processes in a single product:
  - High-speed machining strategies, optimized approach, exit and connections for roughing, rest-roughing, finishing, rest milling and more
  - Support for 3+2 machining (5-axis positioning)
  - Complete gouge protection on tool and holder geometry
  - Tooling library with material/feed/speed/cutting conditions
  - Provides in-process stock models to visualize the part after each machining step and to optimize subsequent toolpaths
- Works with data from any CAD system and creates associative NC toolpaths directly from CAD models
- Multi-threaded architecture saves time: multi-processor, dual-core support and hyper-threading computes toolpaths faster and allows you to continue working in Pro/TOOLMAKER while toolpaths are calculated in the background
- Extends tool life and reduces wear on machines with its optimized toolpaths, feed-rate optimization, and anti-vibration capabilities

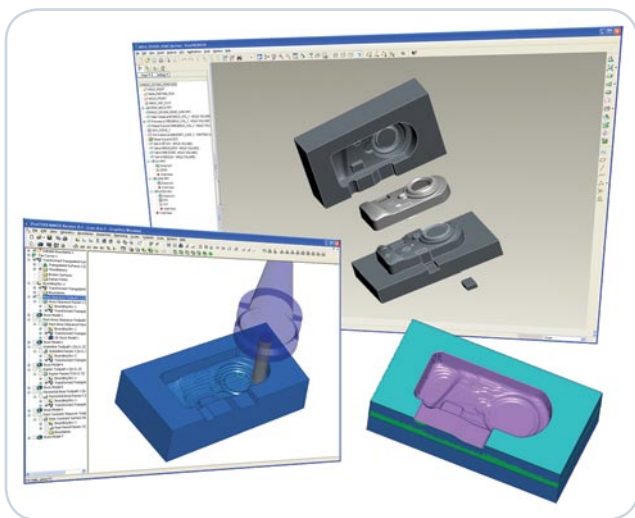

Pro/TOOLMAKER lets you quickly create NC toolpath programs, animate machining on-screen with process times, and view in-process stock models.

### Pro/TOOLMAKER 5-Axis

Leverage this Pro/TOOLMAKER add-on application for more powerful and easy-to-use simultaneous 5-axis machining capabilities.

- Quickly create optimized toolpaths for complex geometries using swarf machining, morph machining, and more
- Save valuable time by automatically converting your 3-axis toolpath programs to 5-axis

- 5-axis machining enables you to leverage shorter tools which reduce machining vibrations, improve quality and increase tool life
- Further reduce costs by reducing the number of machining operations and wear on machines

### Pro/ENGINEER Tool Design

Create the most complex single-cavity and multi-cavity molds and casts with ease. Evaluate mold draft, undercut and thickness problems, and then automatically create parting surface and splitting geometry in a process-driven environment that's simple – even for the occasional user – who needs to create complex tooling quickly.

- Define even the most complex geometry for creating single- and multiple-cavity molds and casts
- Evaluate mold draft, undercut and thickness problems and examine forming and secondary forming dies
- Eliminate data translation errors using an integral CAD/CAM solution from conceptual design to manufacturing
- Reduce the need for redesigns through automatic updating of tooling models, drawings and electrodes
- Eliminate costly rework via interference checking and mold opening simulation

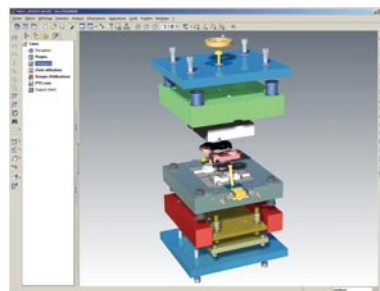

An exploded moldbase in Pro/ENGINEER Expert Moldbase.

### Pro/ENGINEER Expert Moldbase

Work in a familiar 2D environment for moldbase layout – and get all the benefits of 3D! The 2D process-driven GUI offers a catalog of standard and custom components, and updates your model automatically during the development of the moldbase, by providing a catalog of standard and customized components. Your resulting 3D models are then used for interference checking during mold opening, as well as automatic generation of deliverables such as detail drawings and BOMs.

- Speeds the design process through a simple, process-driven workflow that automates moldbase design and detailing
- Includes libraries for 17 moldbase/component suppliers (screws, ejector pins, sliders, cooling fittings)
- Automatic ejector pin, waterline, and fittings functions; automated runners and waterline checks
- Prevents costly rework and reduces cycle time by eliminating mistakes via a 3D environment
- Reduces the need for redesigns by automatically updating tooling models, drawings and electrodes

# Pro/ENGINEER NC and Tooling Solutions

	Prismatic & Multi-Surface Milling	Production Machining	Complete Machining	Pro/TOOLMAKER	Tool Design	Expert Moldbase	Progressive Die	NC Sheetmetal	Computer-Aided Verification
2-Axis Feature-based Machining	●	●	●	●					
3-Axis Milling	●	●	●	●					
4/5-Axis Positioning Milling	●	●	●	●					
4-Axis Turning		●	●						
4-Axis Wire EDM		●	●						
Live Tooling for Turning (Mill/Turn: CBY)			●						
5-Axis Continuous Milling and Contouring Machines			●	*					
Extraction of Manufacturing Annotation Features			●						
Tool and Fixture Library	●	●	●	●					
Manufacturing Process Documentation Pro/PROCESS for Manufacturing	●	●	●						
Automatic Nesting								●	
Punch Press and 2-Axis Laser Programming								●	
GPOST: NC Post-Processor Generator	●	●	●	●				●	
VERICUT for Pro/ENGINEER: NC Simulation	●	●	●						
Automatic Core/Cavity creation					●				
Moldbase Design, including Moldbase Component Library					○	●			
Progressive Die Design							●		
First Article Inspection (compare 3D model with cloud of points)									●
CMM Programming (DMIS output)									●

All of the options above require a seat of Pro/ENGINEER Foundation XE Package with the exception of Pro/TOOLMAKER.

● Capability included

○ Basic moldbase layout functionality

\* Optionally available with purchase of Pro/TOOLMAKER 5-Axis Option

## A Solution for Your Role in Manufacturing

No matter what role you perform in product manufacturing, Pro/ENGINEER has a precision CAM tool that can help you deliver higher-quality products – at a lower cost – in the shortest timeframe possible. Here are additional CAM tools that are helping engineers in a variety of manufacturing disciplines:

### Pro/ENGINEER Progressive Die

Easy-to-use wizards guide you through automatic strip layout definition, cut stamp creation, and placement/modification of die components. You can eliminate error-prone manual tasks by automatically creating clearance cuts, drilled holes, and documentation.

### Pro/ENGINEER NC Sheetmetal

Boost productivity by automatically creating and optimizing toolpaths using standard and form tools. Use auto-nesting to maximize your sheet area, thus reducing scrap and material costs and cutting lead times.

### Pro/ENGINEER Computer-Aided Verification

Gain absolute confidence in the QA process by performing digital inspections of machined parts and assemblies. The exactness of a digital-quality checking process saves time, effort and money.

### Pro/ENGINEER Plastic Advisor

By simulating the plastic-filling process for injection-molded parts, you can design-for-manufacturability, uncover problems, and propose remedies, thus reducing development time and expense.

Take a closer look and discover the power of Pro/ENGINEER NC and Tooling solutions at [www.ptc.com/go/cam](http://www.ptc.com/go/cam)

©2008, PTC (Parametric Technology Corporation) – All rights reserved under copyright laws of the United States and other countries. Information described herein is furnished for informational use only, is subject to change without notice, and should not be construed as a guarantee, commitment, condition or offer by PTC. PTC, the PTC Logo, Pro/ENGINEER, Windchill ProjectLink, and all PTC product names and logos are trademarks or registered trademarks of PTC and/or its subsidiaries in the United States and in other countries.